

GENERAL FEATURES

- Combine the characteristics of lead acid battery and super capacitor
- Long life cycle service design, excellent PSoc and cyclic performance
- High power, rapid charging and discharging
- Unique grid and lead pasting design
- Extreme temperature tolerance

APPLICATIONS

- Energy storage system
- Smart power grids and micro grids system
- Hybrid energy storage system
- New energy such as Generator and battery hybrid energy system



DIMENSIONS & WEIGHT

Length(mm)	328±1
Width(mm)	172±1
Height(mm)	218±1
Total Height(mm)	222±1
Weight(kg)	32.0±3%

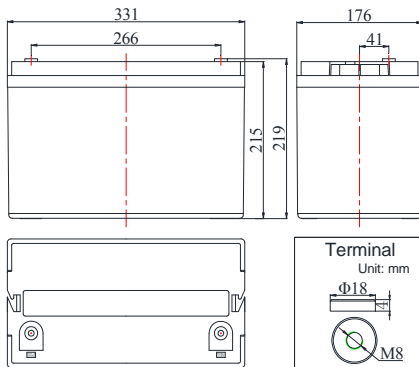

COMPLIED STANDARDS

IEC 60896-21/22	JIS C8704
YD/T799	BS6290 part4
GB/T 19638	UL 1989

TECHNICAL SPECIFICATIONS

Nominal Voltage		12V(6 cells per unit)
Design Floating Life @25°C		20 Years
Nominal Capacity @25°C(20 hour rate@5.00A,10.50V)		100.0Ah
Capacity @25°C	10 hour rate (9.28A,10.8V)	92.8Ah
	5 hour rate (17.2A,10.5V)	86.0Ah
	1 hour rate (60.2A,9.60V)	60.2Ah
Internal Resistance	Full Charged Battery@25°C	≤6.0mΩ
Ambient Temperature	Discharge	-30°C~60°C
	Charge	-30°C~60°C
	Storage	-30°C~60°C
Max. Discharge Current@25°C		1000A(5s)
Capacity affected by Temperature (10 hr Capacity)	40°C	108%
	25°C	100%
	0°C	90%
	-15°C	70%
Self-Discharge@25°C per Month		3%
Charge (Constant Voltage) @25°C	Standby Use	Initial Charging Current Less than 30.0A Voltage 13.6-13.8V
	Cycle Use	Initial Charging Current Less than 30.0A Voltage 14.4-14.7V



BATTERY DISCHARGE TABLE

Discharge Constant Current per Cell (Amperes at 25°C)

F.V/Time	5min	10min	15min	20min	25min	30min	35min	40min	45min	60min	90min	2h	3h	4h	5h	6h	7h	8h	10h	12h	20h
1.60V	271.9	173.4	147.3	120.0	105.7	94.2	83.1	75.6	69.1	60.2	48.6	38.2	26.8	22.0	18.2	15.3	13.4	12.0	10.19	8.57	5.30
1.65V	267.0	170.2	144.7	118.0	103.9	92.5	81.6	74.2	67.9	59.0	47.6	37.4	26.3	21.5	17.9	14.9	13.2	11.8	10.00	8.42	5.20
1.67V	264.4	168.6	143.1	116.1	103.0	91.7	81.1	73.8	67.5	58.4	47.3	37.1	26.1	21.3	17.6	14.8	13.1	11.7	9.89	8.35	5.15
1.70V	259.0	165.5	140.3	114.0	101.1	89.8	79.8	72.5	66.4	57.2	46.3	36.8	25.9	21.1	17.5	14.7	13.0	11.6	9.69	8.21	5.11
1.75V	257.0	163.8	139.3	112.6	99.5	89.0	78.7	71.6	65.5	56.6	45.9	36.0	25.3	20.8	17.2	14.5	12.8	11.4	9.59	8.08	5.00
1.80V	248.9	158.5	134.5	110.1	96.6	86.2	76.4	69.5	63.5	54.9	44.5	34.6	24.3	19.8	16.6	14.0	12.2	10.9	9.28	7.81	4.85
1.85V	234.0	149.5	126.6	103.3	90.6	81.0	71.8	65.3	59.7	51.7	41.8	32.8	22.9	18.7	15.6	13.2	11.6	10.3	8.71	7.34	4.41

Discharge Constant Power per Cell (Watts at 25°C)

F.V/Time	5min	10min	15min	20min	25min	30min	35min	40min	45min	60min	90min	2h	3h	4h	5h	6h	7h	8h	10h	12h	20h
1.60V	509.5	326.9	277.8	227.3	201.2	179.9	158.8	144.8	132.5	115.5	93.1	73.3	51.5	42.1	34.8	29.2	25.8	23.0	19.5	16.5	10.30
1.65V	502.2	321.9	274.3	224.5	198.4	177.4	156.0	141.9	130.6	113.4	91.4	72.1	50.6	41.4	34.4	28.7	25.4	22.7	19.2	16.2	10.20
1.67V	498.6	319.3	271.8	222.3	196.8	175.8	155.2	141.5	129.8	112.2	90.8	71.4	50.2	41.0	34.0	28.6	25.2	22.5	19.1	16.1	10.15
1.70V	494.1	314.7	267.5	218.1	193.3	172.4	153.0	139.2	127.8	110.1	88.9	70.8	49.7	40.6	33.8	28.3	25.0	22.3	18.7	15.8	10.10
1.75V	491.4	312.1	265.7	215.3	190.5	170.8	151.1	137.6	125.8	109.0	88.1	69.4	48.7	39.9	33.1	27.9	24.6	21.9	18.5	15.6	9.90
1.80V	477.0	303.4	257.7	211.4	185.5	165.5	146.7	133.8	122.1	105.6	85.4	66.8	46.9	38.1	31.9	26.8	23.5	21.0	17.9	15.1	9.60
1.85V	449.8	288.2	244.3	200.0	175.8	157.0	139.2	126.6	116.0	100.4	81.0	63.7	44.6	36.4	30.3	25.6	22.5	20.0	16.9	14.3	8.73

Note The above data are average values, and can be obtained within 3 charge/discharge cycles. These are not minimum values. Cell and battery designs/specifications are subject to modification without notice. Contact **POWERGEN** for the latest information.

POWERGEN POWERGEN BATTERY: Constant, Safe POWER for YOU

PERFORMANCE CHARACTERISTICS

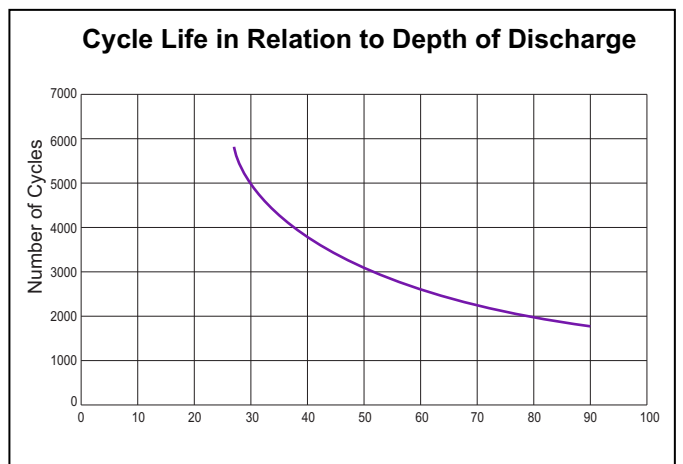
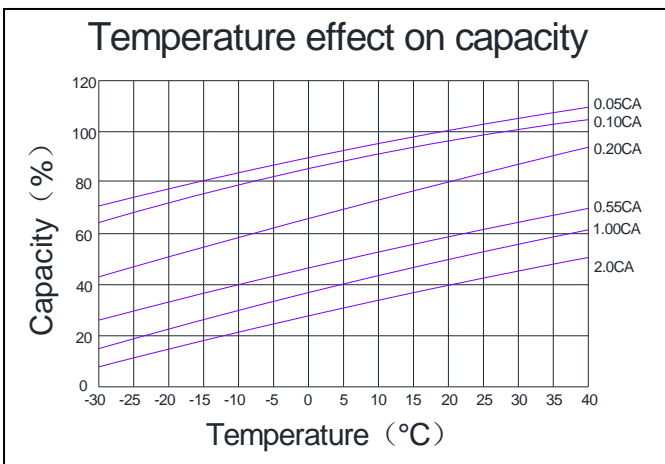
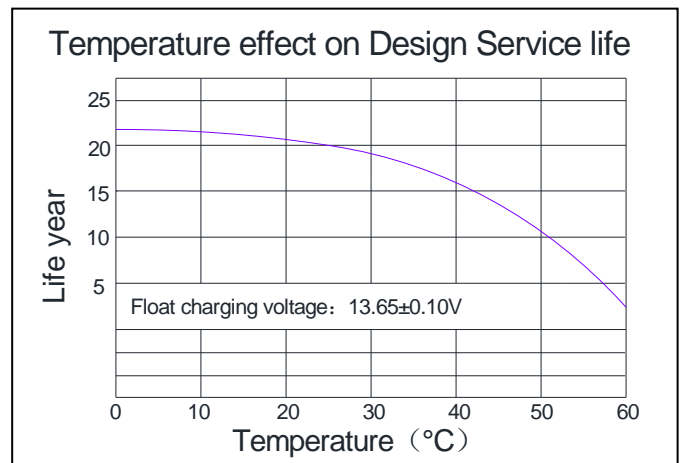
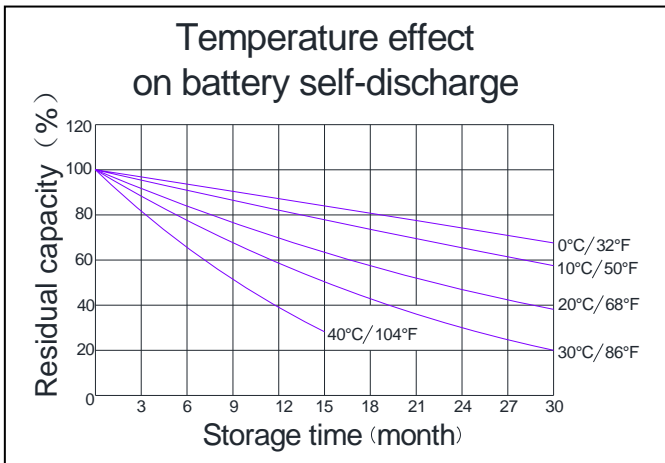
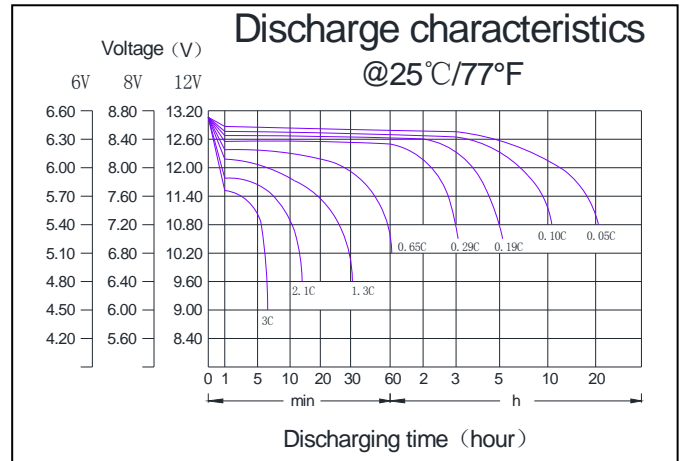
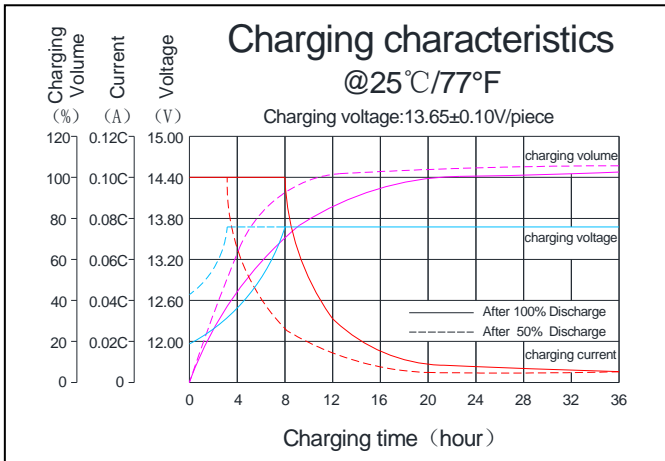

BATTERY CONSTRUCTION

Component	Positive plate	Negative plate	Container & Cover	Safety valve	Terminal	Separator	Electrolyte	Pillar seal
Features	Rare earth alloy grid with good corrosion resistance	Unique anode formula, high purity material, low self-discharge rate	ABS (UL94-V0 optional)	Flame resistance, aging resistance	Female Copper Insert M8(torque:7~9 N.m)	AGM separator with organic fiber, longer service life	Gradual change gel electrolyte (with patent)	Anti-corrosion elastic O ring, two layers epoxy seal technology

AKÜMSER AKÜ AS.

Add: Akcaburgaz Mah. Alkop Cad. 319. Sok No:9/3 ESENYURT-İSTANBUL

Tel: 444-4-148 Email: info@akumser.com

POWERGEN

[HTTP://WWW.AKUMSER.COM](http://www.akumser.com)